

3M™ Fire Protection

Design Specification Sheet : 3M Tuck-In Wrap Strip Concrete Wall

Through Penetration	Construction Type	FRR	Compliance Report
PVC or PVC-U Pipe	Concrete, AAC, masonry or solid block wall min 100mm thick	Up to -/120/120	AS 1530.4:2014 & AS 4072.1-2005 BRANZ FC10453 Page 11 System/FPA Register ID# FC087

3M™ Fire Barrier Tuck-In Wrap Strip Fire Stopping System

PVC or PVC-U Pipes in 100mm Concrete, AAC or Masonry Walls

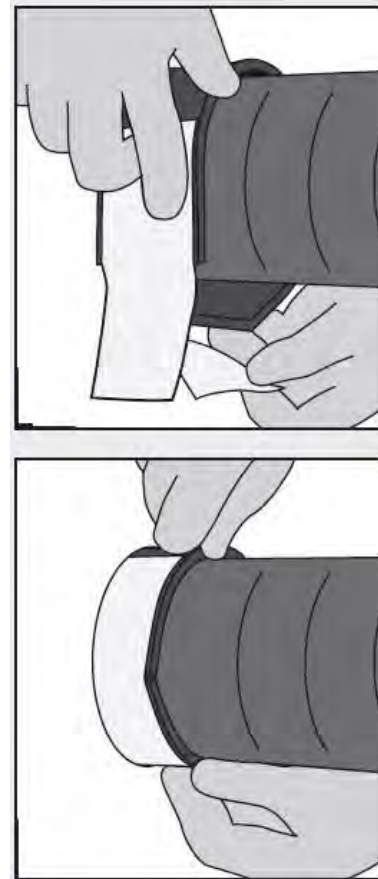
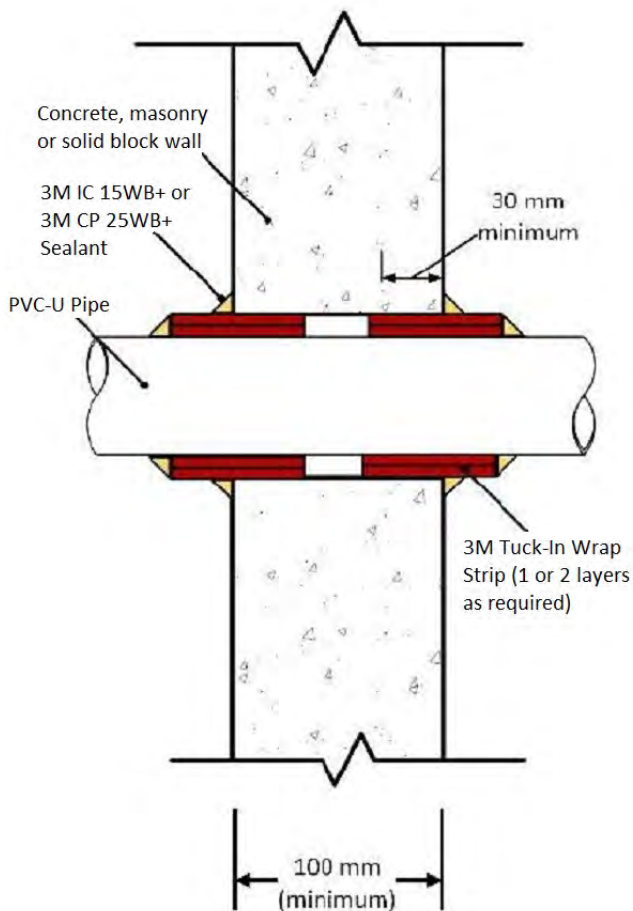

Installation

1. PVC-U Pipe, pipe sizes as per Table 1
2. 3M™ Tuck-In Wrap Strip fitted closely around the pipe and pushed into the wall leaving approx 20mm protruding from the wall each side.
3. Single layer systems require a 10mm deep bead of 3M IC15WB+ Sealant within the annular space between the Wrap Strip and the wall (minimum annular space 10mm).
4. Double layer systems with the minimum annular gap of 10mm do not require 3M IC15WB+ Sealant within the gap but there must be a fillet of at least 5mm applied at the wall/Wrap junction (see illustration above).
5. Finally apply a bead of 3M IC15WB+ Sealant around the Wrap Strip/pipe junction.

NOTE: The more highly intumescent 3M CP 25WB+ sealant may be substituted for 3M IC 15WB+ (Warringtonfire RIR 23263 pg 4)

Table 1 - PVC-U Pipe and Aperture Size for 3M™ Tuck-In Wrap Strip in Concrete Walls

Pipe Outside Diameter	Minimum Annular Gap	Maximum Annular Gap	Pipe wall Thickness	No. of Wraps	FRR
Up to 50mm	10mm	20mm	Up to 3.7mm	1	-/120/120
Up to 110mm	10mm	20mm	Up to 5.3mm	2	-/120/120
Up to 110mm	10mm	20mm	Up to 3.2mm	1	-/120/90
Up to 110mm	10mm	20mm	Up to 5.3mm	1	-/60/60

NOTE: Where the FRR of the wall is less than the system FRR in Table 1 above then the lower FRR must be used.

3M Australia Pty Ltd
Industrial Adhesives & Tapes Division
 Bldg A, 1 Rivett Road,
 North Ryde, NSW 2113
 Phone 136 136 (Option 2)
 Email 3mindustriaucs@mmm.com
 Web www.3m.com.au

3M New Zealand Ltd
Industrial Adhesives and Tapes Division
 94 Apollo Drive, Rosedale
 Auckland 0632
 Phone 0800 474 787
 Email 3mnzibt@mmm.com
 Web www.3m.co.nz

User is responsible for determining whether the 3M product is fit for a particular purpose and suitable for user's application. Limitation of Liability. Except where prohibited by law, 3M will not be liable for any loss or damage arising from this 3M product, whether direct, indirect, special, incidental or consequential, regardless of the legal theory asserted, including warranty, contract, negligence or strict liability. 3M and Interam are a trademark of 3M Company.